

DWG NO. D-039-0003 SHT. REV. I

REVISIONS			
REV. NO.	DESCRIPTION	BY	DATE
H 0179	REDRAW TO COMPUTER	RM JK	8-14-89
I 0706	ADD METRIC DIM	RM JK	7-31-92

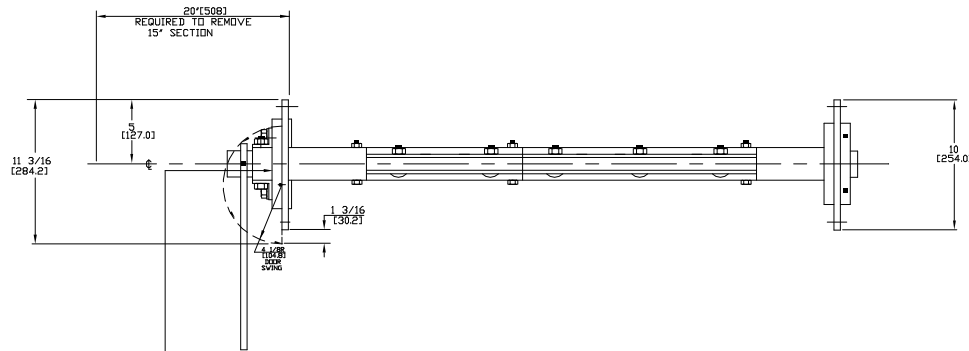

'B' BELT WIDTH	'W' WIDTH BETWEEN FLANGES		'A' MAX UNIT WIDTH
	MAX	MIN	
16 (395)	42 (1066.8)	15 (381.0)	54 (1371.6)
18 (457.2)	48 (1219.2)	21 (533.4)	60 (1524.0)
24 (609.6)	54 (1371.6)	27 (685.8)	66 (1676.4)
30 (762.0)	60 (1524.0)	33 (838.2)	72 (1828.8)
36 (914.4)	66 (1676.4)	39 (990.6)	78 (1981.2)
42 (1066.8)	72 (1828.8)	45 (1143.0)	84 (2133.6)
48 (1219.2)	78 (1981.2)	51 (1295.4)	90 (2286.0)
54 (1371.6)	84 (2133.6)	57 (1447.8)	96 (2438.4)
60 (1524.0)	90 (2286.0)	63 (1600.2)	102 (2590.8)
66 (1676.4)	96 (2438.4)	69 (1752.6)	108 (2743.2)
72 (1828.8)	102 (2590.8)	75 (1905.0)	114 (2895.6)
84 (2133.6)	114 (2895.6)	87 (2209.8)	126 (3200.4)

NOTE: ALL DIMENSIONS IN [] ARE IN MILLIMETERS

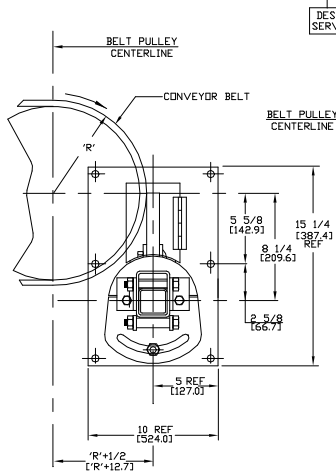

DESIGNATED SERVICE END

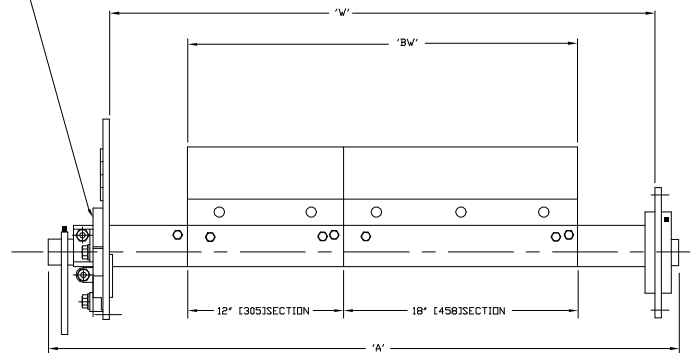

NOTE: 2" X 2" SUPPORT TUBE IS SOLID (1 PIECE) CONSTRUCTION. ALLOWANCE MUST BE MADE FOR INITIAL INSTALLATION.

RIGHT HAND INSTALLATION SHOWN

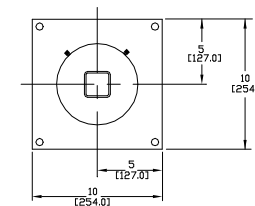

REFER TO C-039-0001 FOR INSTALLATION INSTRUCTIONS

REFER TO DWG. D-036-0020 FOR L.H. & R.H. INSTALLATIONS.

THIS DRAWING IS COMPUTER GENERATED.			
DWN RM	DATE 7-26-82	CONVEYOR COMPONENTS COMPANY	
CRD CL	DATE 8-4-82	130 SELTZER ROAD, CRISWELL, MI. 48422	
APP JK	DATE 9-1-82	MODEL RLP-350 CHUTE MOUNT	REFERENCE DIMENSIONS
		PART NO. DWG NO.	REV
		D-039-0003	I
SCALE 1/4"=1'		SHT.	