

DWG. NO. C0360015 SHT. REV. 1-1 G

REVISIONS				
REV.	E.C.D.	DESCRIPTION	DATE	BY APP'D
G	0742	ADD PIVOT LOCATIONS	11/05/92	WR JK

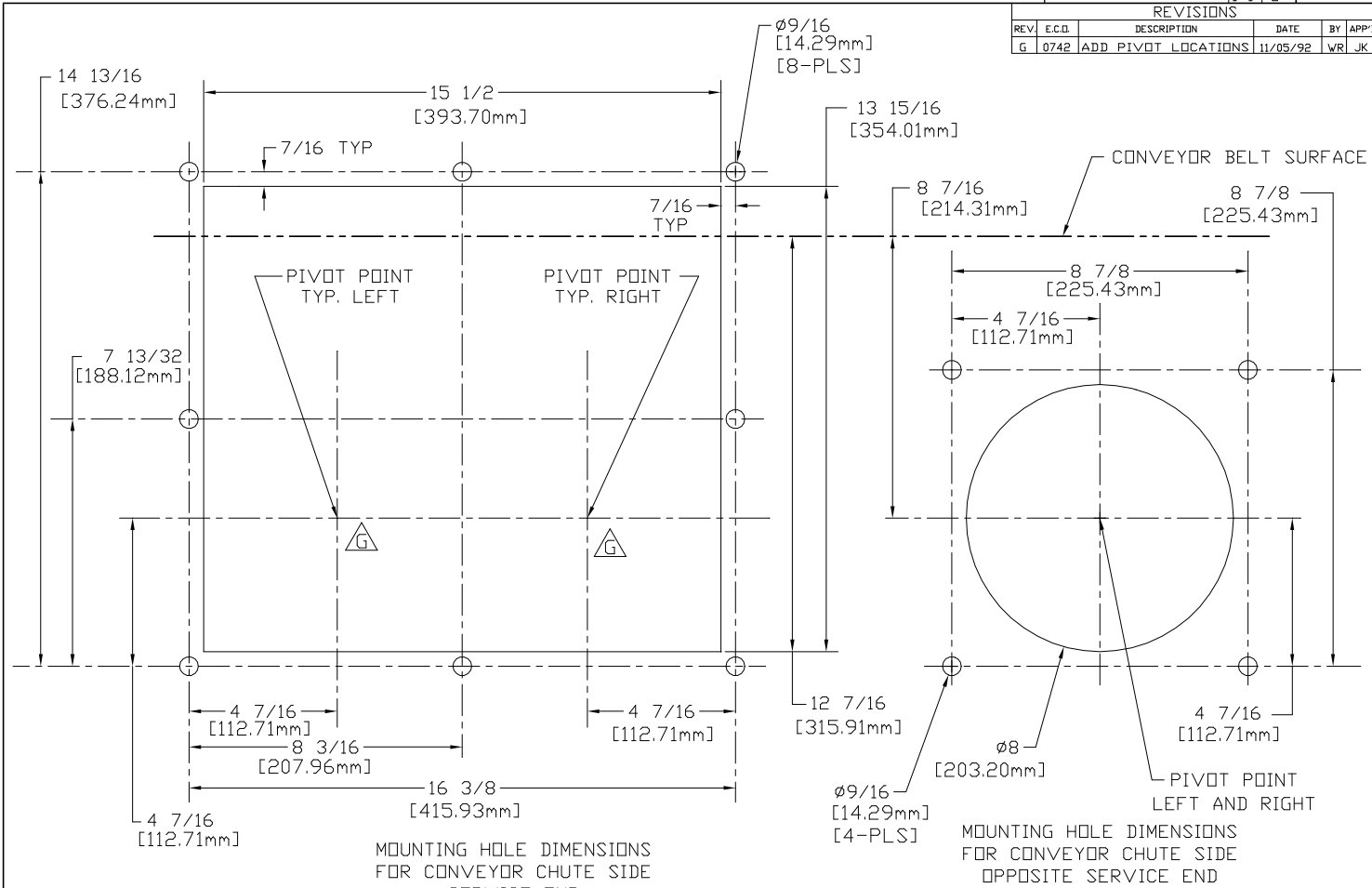

NOTES:

1. MOUNTING HOLES ARE DRILLED TO ACCEPT 1/2-13 BOLTS WHICH ARE SUPPLIED.
2. THE PIVOT POINT ON THE OPPOSITE SERVICE END MUST BE DIRECTLY ACROSS FROM THE SERVICE END PIVOT.
3. FURTHER INSTRUCTIONS TO COMPLETE THE INSTALLATION ARE CONTAINED ON DWGS. D-036-0002, D-036-0003

NOTE: ALL DIMENSIONS IN [] ARE IN MILLIMETERS

USE WITH DWG D-036-0002, D-036-0003

THIS DRAWING IS COMPUTER GENERATED.

DWN_RM	DATE 07/06/82	CONVEYOR COMPONENTS CO.
CHKD_CLO	DATE 07/08/82	130 SELTZER RD, CROSWELL, MI 48422
APP_JK	DATE 08/05/82	MODEL RFA-358 INSTALLATION INSTRUCTIONS
THIS PRINT IS THE PROPERTY OF CONVEYOR COMPONENTS CO. AND MUST NOT BE USED IN WHOLE, OR PART WITHOUT WRITTEN PERMISSION.		
PART NO.	DWG. NO. C0360015	REV. G
SCALE HALF		SHT. 1-1

DWG. NO. C0360015 SHT. REV. 1-1 G